



SERVOTOUGH Fluegas (2700) Gas Analyser

Installation Manual

Part Number: 02700005C
Revision: 3
Language: UK English

This page intentionally blank

Servomex 2700

Combustion Gas Analyser Installation Manual

Reference: 02700/005C/3
Order as part number: 02700005C

NOTES

TABLE OF CONTENTS

1	INTRODUCTION	1
1.1	Warnings, Cautions and Notes	1
1.2	Scope of this manual	1
1.3	General safety information	3
1.4	Hazardous Area approval and certification	4
1.5	Unpacking	5
2	SERVOMEX 2700 OVERVIEW	7
2.1	Overview	7
2.2	Sensor head description	8
2.3	Control unit description	8
3	INSTALLATION OF SENSOR HEAD AND PROBE TUBE	9
3.1	Installation location	9
3.2	Flange mounting arrangements	13
3.2.1	Standard installation	13
3.2.2	Weld-on flange installation	14
3.2.3	Adaptor flange installation	14
3.2.4	High temperature stand-off installation	16
3.2.5	Thermal spacer installation	18
3.2.6	Probe retention flange installation	20
3.3	Sample probe installation	22
3.3.1	Open-ended and unsupported filtered metal probe installation	22
3.3.2	Open-ended ceramic probe installation	22
3.3.3	Supported probe installation	26
3.4	Calibration and utilities supplies	28
3.5	Electrical installation	30
4	INSTALLATION OF CONTROL UNIT	35
4.1	Installation location	35
4.2	Electrical installation	38
4.3	Enclosure purge connection	41
5	INITIAL STARTUP PROCEDURE	45
5.1	Gases required	45
5.2	Visual inspection	46
5.3	Initial power up	46
5.4	Analogue output span setup	47
5.5	Sensor head sample flow adjustment	47
5.6	Combustibles sensor zero adjustment	47
5.7	Sensor calibration	48
6	MAINTENANCE AND SERVICING	49
Appendix A	INTERCONNECTING WIRING SCHEDULES	51

LIST OF FIGURES

Figure 1	Servomex 2700 sensor head and control unit overview	7
Figure 2	Servomex 2700 sensor head dimensions (typical)	12
Figure 3	Adaptor flange installation	15
Figure 4	High temperature stand-off flange installation	17
Figure 5	Thermal spacer installation	19
Figure 6	Probe retention flange installation	21
Figure 7	Sample probe and filter construction	24
Figure 8	Supported probe construction	25
Figure 9	Probe support tube installation	27
Figure 10	Sensor head terminal enclosure detail.	32
Figure 11	Control unit installation	37
Figure 12	Control unit enclosure detail	40
Figure 13	Oxygen sensor only interconnection wiring schematic	52
Figure 14	Combustibles only interconnection wiring schematic	54
Figure 15	Dual sensor interconnection wiring schematic	56

LIST OF TABLES

Table 1	Sensor head operating environment	10
Table 2	Sensor head adaptor flange kits.	14
Table 3	Sample probe part numbers.	23
Table 4	Sensor head electrical power connections.	31
Table 5	Control unit operating environment	36
Table 6	Control unit electrical power voltage selection.	39
Table 7	Control unit electrical power connections.	42
Table 8	Relay output connections.	42
Table 9	Analogue output connections	43
Table 10	User remote dry contact inputs	43
Table 11	Gas requirements.	45
Table 12	Interconnecting cable requirements.	51
Table 13	Oxygen sensor only interconnecting wiring	53
Table 14	Combustibles only interconnecting wiring	55
Table 15	Dual sensor interconnecting wiring	57

1 INTRODUCTION

1.1 Warnings, Cautions and Notes

This manual includes **WARNINGS**, **CAUTIONS** and **NOTES** which provide information relating to the following:

WARNINGS

Hazards which could result in personal injury or death

CAUTIONS

Hazards which could result in damage to equipment or property

NOTES

Alert the user to pertinent facts and conditions



CAUTION – refer to the Installation Manual

1.2 Scope of this manual

This manual covers the installation of the Servomex 2700 Combustion Gas Analyser and the various options that are available.

- Refer to the QuickStart Manual or Technical Data Sheet for latest technical specification.
- Addresses for technical assistance and spares are given on the rear cover.
- A QuickStart Manual is available, part number **02700003C**.
- A Service Manual is available for use by qualified personnel, part number **02700002C**.

About this manual

Reference: 02700/005C/3

Order as part number: 02700005C

CE Marking

The Servomex 2700 analyser carries the CE mark which indicates conformity with the European Community Directives on CE Marking (93/68/EEC), Electromagnetic Compatibility (EMC 89/336/EEC) and Low Voltage Directive (LVD 73/23/EEC).

Servomex 2700 control units are marked in conformity with the Explosive Atmospheres (ATEX) Directive (94/9/EC) when fitted with a European hazardous area certification marking plate.

1.3 General safety information

Specific standards of safety are not included in this manual, since requirements of relevant authorities vary widely. The safety precautions described in the following installation instructions ensure that the existing safety features are not impaired during installation. The precautions do not guarantee a safe installation if other relevant safety codes are ignored.

WARNING

- The electrical power used in this equipment is at a voltage high enough to endanger life.
- It is essential that only suitably trained and competent personnel are allowed to access hazardous live parts by removing or opening covers of the analyser.
- The sensor head is heated and may be attached to a hot flue. The external surfaces will be uncomfortably hot even after power down for several hours. Exercise care when handling the sensor head even when un-powered on a hot flue.
- The installer must be satisfied that the Servomex 2700 installation conforms to the relevant safety requirements, National Electrical Code and any other local regulations and that the installation is safe for any extremes of conditions which may be experienced in the operating environment of the analyser.
- This appliance must be connected to a protective earth.
- The electrical installation must include a means of isolating electrical power by a switch or circuit breaker external to the analyser and within easy reach of the operator. It must be marked as the disconnecting device for the equipment.
- To comply with the European Community EMC Directives for industrial environments the interconnecting cables, mains supply, relay contact outputs and/or analogue output signals should be screened or provide equivalent protection.
- The Servomex 2700 sensor head aspirator supply is suitable for use with compressed air only. Flammable gases must not be used for the aspirator supply.
- The Servomex 2700 sensor head is not suitable for use in hazardous areas / locations without the use of appropriate safety purge equipment.
- Servomex 2700 EU2/UK2/FM2/CS2 approved control units must be used if the installation is in a Category 3/Zone 2/Division 2 hazardous area/location.
- Flanges and flange adaptors supplied by Servomex DO NOT conform to ANSI or any other Standards body and must only be used in Servomex specified applications with process pressure not greater than 5psig.

NOTE

The branch circuit supplying power to this instrument should be installed with a suitable fuse rated not greater than 15A or a suitable over-current protection device set not greater than 15A.

1.4 Hazardous Area approval and certification

Copies of all hazardous area certificates are provided in the Certificate Manual (part number 02700008C) which is supplied with each hazardous area certified unit. In summary, the Servomex 2710 control unit is certified for use in Category 3/Zone 2/ Division 2 areas (for both gas and dust hazards) and is available with the following hazardous area approvals:

Europe

Approved as Ex ic nA nC IIC T5 Gc, Ex tc IIIB T75°C Dc (Ta = -10°C to +55°C) for ATEX Group II, Category 3, Gas and Dust hazardous atmospheres. ITS10ATEX47005X. In addition the serial number and year of manufacture are marked on an external rating plate.

United States

Factory Mutual approved as non-incendive for:
Class I, Div. 2, Groups A,B,C & D.
Class II, Div. 2, Groups F & G.
Class III, Div. 1 & 2.
Enclosure Type 4X.
T5. Ambient Temperature 55°C max.

Canada

CSA: suitable for use in:
Class I, Div. 2, Groups A,B,C & D.
Class II, Div. 1, Groups E,F & G.
Class III, Div. 1.
Enclosure Type 4X.
T5. Ambient Temperature 55°C max.

WARNING

To minimise the risk of propagating brushed discharges, do not install in a high velocity dust laden environment.

1.5 Unpacking

WARNING

The Servomex 2700 sensor head and control unit weigh approximately 17Kg (37.5lb) and 11Kg (24.3lb) respectively and care must be taken when handling.

- Remove the Servomex 2700 components from their packing and inspect for obvious external damage.
- If damage has occurred, inform Servomex or its agent immediately.

Retain all packing and shipping information for future use.

This page is intentionally blank

2 SERVOMEX 2700 OVERVIEW

2.1 Overview

Figure 1 Servomex 2700 sensor head and control unit overview

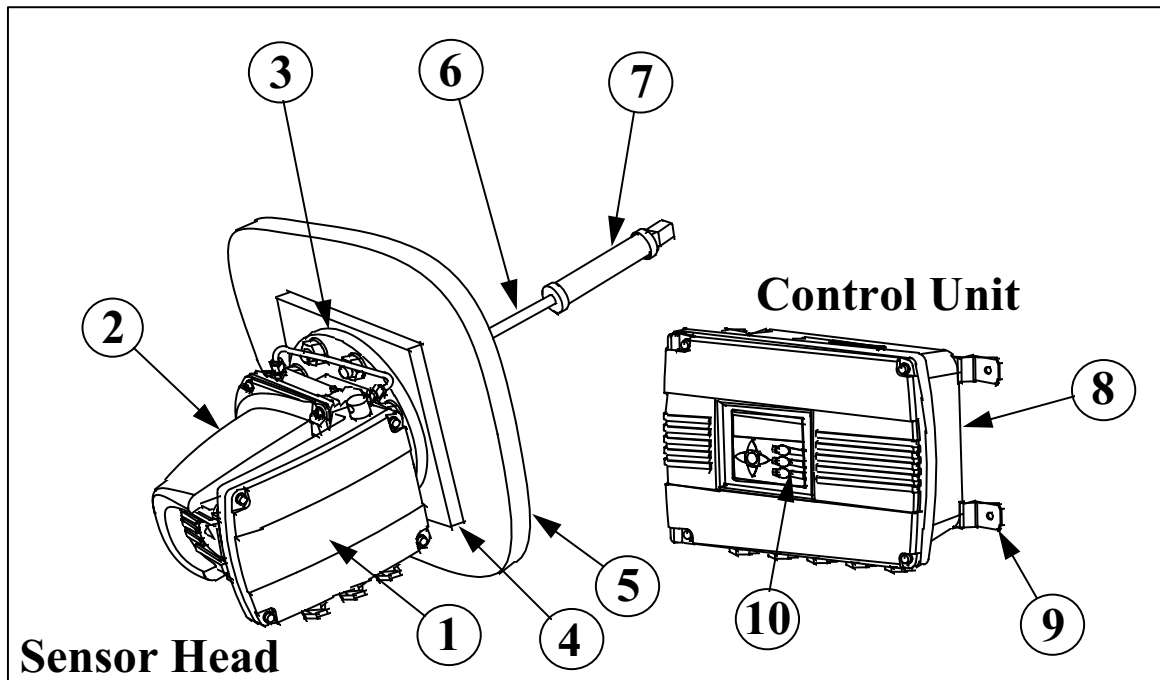

Key to Figure 1 – Servomex 2700 sensor head and control unit overview

1	Terminal enclosure cover	6	Sample probe
2	Sensor head cover	7	Sample probe filter
3	4" mounting flange	8	Control unit
4	4" weld-on flange	9	Wall mounting brackets
5	Flue/process wall	10	Keypad and display

The Servomex 2700 Combustion Gas Analyser measures combustion and similar gases to provide an analysis of the oxygen concentration and/or the level of unburned combustibles. The analyser comprises two separate units which may be mounted up to 300m (975ft) apart for oxygen only and 100m (325ft) apart whenever the combustibles measurement option is fitted.

An overall system will consist of sensor head/sample probe/filter mounted directly onto the flue wall and a control unit mounted remotely from the sensor head. The user must ensure that both the sensor head and control unit have their own separate power supply. Also required is a compressed air supply with a pressure regulator to control the aspirator air supply.

An optional utilities unit is available to supply the sensor head with calibration gases and compressed air.

2.2 Sensor head description

The sensor head is flange mounted on to the flue wall and houses the measurement sensors in a heated enclosure. A probe tube projects through the duct wall into the process gas to extract a gas sample for analysis. A comprehensive range of sample probes and filters are available to enable the analyser to be used in a wide range of applications and process conditions. Electrical connections are made to a terminal box located on the side of the sensor head.

2.3 Control unit description

The control unit houses the drive electronics, microprocessor, keypad, display and user wiring connections. The control unit may be either wall, surface or panel mounted. Electrical connections are made via conduit entries located on the bottom of the control unit enclosure.

3 INSTALLATION OF SENSOR HEAD AND PROBE TUBE

3.1 Installation location

Refer to Figure 2.

NOTE

All Servomex adaptor flanges, interface flanges, probe support tubes, stand-offs and thermal spacers, including the integral flange on the sensor head, are suitable for fitting onto the standard flanges (raised face [$<1.6\text{mm}$] or flat faced). They do not comply with any national or international standards and the analyser's maximum process pressure is limited to 5psig.

Select a location which allows convenient access for installation and maintenance to the terminal box enclosure. The sensor head is supplied with a 4" flange for direct attachment to a flue wall.

The Sensor Head may be mounted in any orientation, except with the terminals box directly above the sensor enclosure or with the mounting flange facing directly upwards.

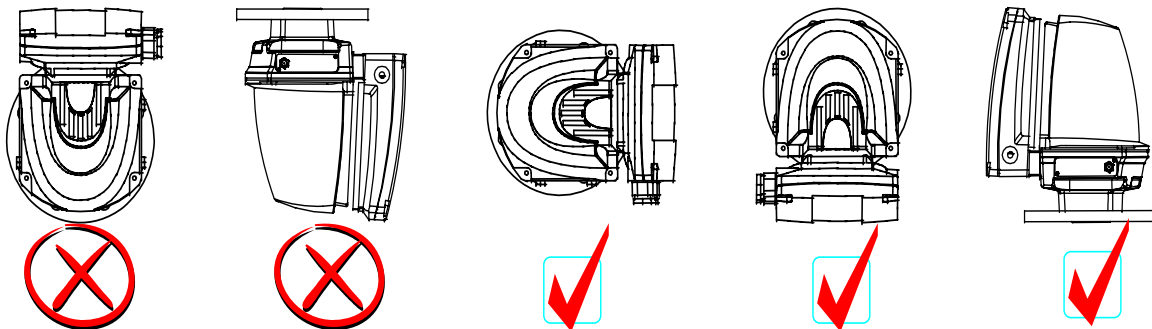

Ensure that the operating ambient temperature is in the range of -20°C to $+70^{\circ}\text{C}$ and that the Sensor Head is protected from radiant heat sources or from direct sunlight (in ambient Temperatures over 30°C). This can be achieved by installing a Heat Shield between the Sensor Head and the source; a thin metal sheet is usually adequate.

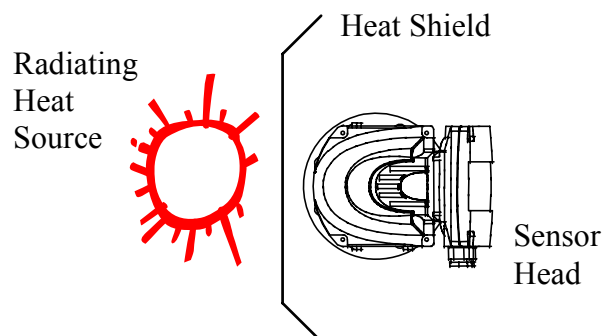

Operating environment conditions for the sensor head are given in Table 1

Table 1 – Sensor head operating environment	
Item	Specification
Ambient operating temperature	-20°C to +70°C (-4°F to +158°F)
Storage temperature	-30°C to +80°C (-22°F to +176°F)
Ingress protection	IP66 and NEMA 4X
AC power supply Factory set for either a) 100-120Vac 50/60Hz b) 220-240Vac 50/60Hz	a) 100-120Vac -15% +10% (Min. 85V – Max. 132V) b) 220-240Vac -15% +10% (Min. 187V – Max. 264V)
Altitude	Up to 2000m
Installation category	Category II. Local level power distribution with over-voltage withstand up to 2500V (in accordance with IEC 664).
Pollution degree	The sensor head/terminal box is rated Pollution Degree 2 (in accordance with IEC 664). The sample probe protruding into the flue and the adjacent face of the flange is rated Pollution Degree 4 (in accordance with IEC 664). <i>See Note 1</i>
Relative humidity	0 to 80% RH
<p><i>Note 1:</i> Where the installation is such that the enclosure ingress protection IP66/Type 4X is maintained and the covers remain securely fitted, the apparatus is suitable for use in locations where there may be significant deposits of nonflammable dusts or fibres (Pollution Degree 4) and/or where there may be drips, splashes of water, prolonged exposure to rain or subjected to hose down.</p> <p>The covers may be removed during installation or servicing only if there is negligible risk of pollution or contamination of the electronic circuits contained within the enclosures and if the covers are securely replaced immediately after the operation is completed. Refer to Section 6.</p>	

CAUTIONS

- Do not lift the sensor head by the compressed air pipe that is connected between the solenoid valve and the bulkhead fitting.
- The anti-seize compound (part number 1761-3211) and ROCOL ASP dry film anti-scuffing paste are the only recommended release compounds. The use of "Silver Goop" or other similar release agents may result in permanent damage to the combustibles sensor (if fitted).

Figure 2 Servomex 2700 sensor head dimensions (typical)

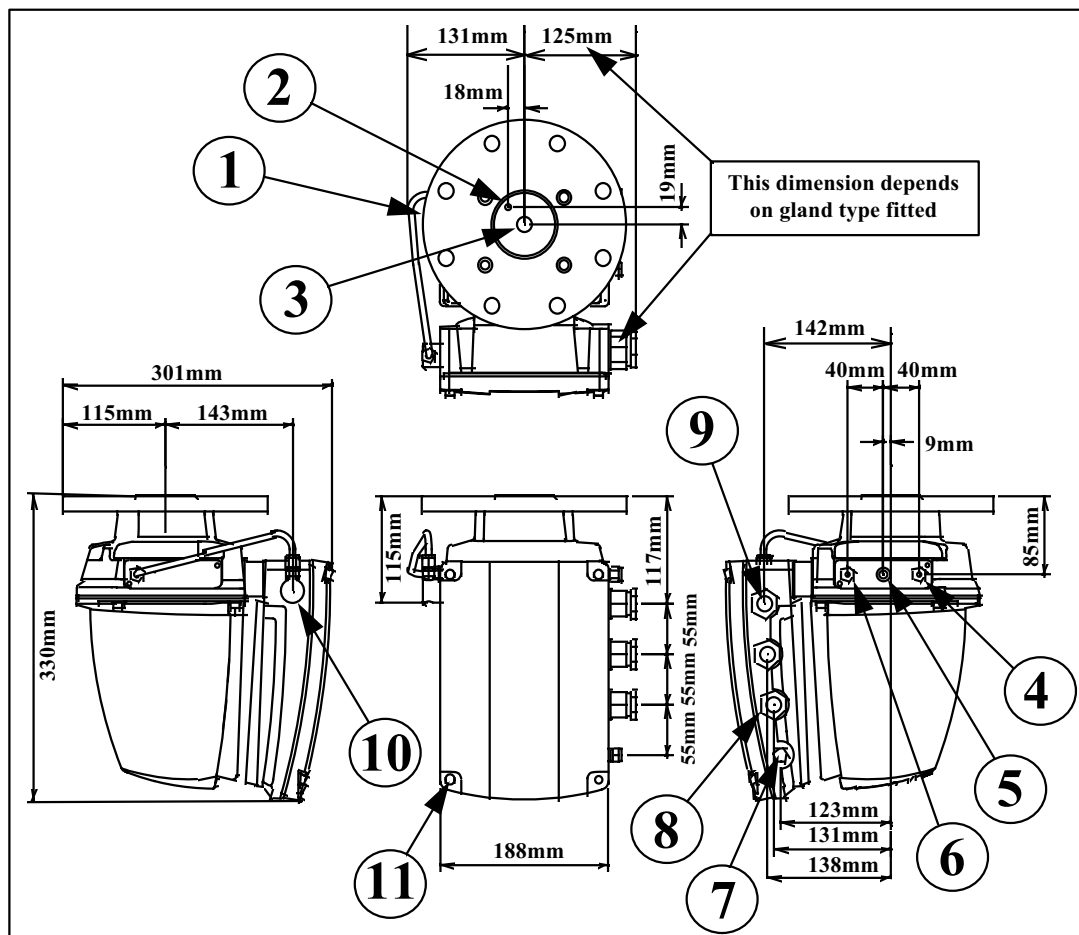

Key to Figure 2 – Servomex 2700 sensor head dimensions

- 1 Analyser mounting flange 4"
- 2 Sample vent port 1/8" NPT (INT)
- 3 Sample probe connection 1/2" NPT (INT)
- 4 Calibration gas inlet 1/4" OD compression fitting
- 5 Purge gas exit, 1/4" NPT (INT), or breather fitting
- 6 Unused Entry
- 7 Purge gas entry, 1/4" NPT (INT) or blanking plug
- 8 Signal cable entry 3/4" NPT (INT) or specified adaptor
- 9 Mains cable entry 3/4" NPT (INT) or specified adaptor
- 10 Aspirator air supply inlet 1/8" NPT (INT)
- 11 M6 screws (4 off)

3.2 Flange mounting arrangements

CAUTION

The user should ensure that the flue wall is strong enough to support the weight of the sensor head and sample probe tube.

SPECIAL INSULATION NOTES

- When a length of stand-off tube is used to secure the mounting flange to the flue it should be insulated efficiently to prevent problems occurring due to excessive heat loss to the atmosphere.
- Always minimise the length of this stand-off tube (<100mm typical).

NOTES

- Ensure that mounting bolts are tightened evenly to prevent the sensor head from tilting, damaging the gasket and causing leaks.
- The sensor head must not be left un-powered when mounted on an active flue. If the sensor head is not to be fitted immediately then a blanking flange should be used. Do not plug the hole with the sensor head.
- Included in the installation kit is a sachet of anti-seize compound (part number 1761-3211) to be used on the sensor head mounting bolts and studs. Failure to use the anti-seize compound may make the fittings difficult to remove.

3.2.1 Standard installation

The sensor head is provided with a 4" flange. The flange has 8 off 19mm diameter holes at 45° intervals on a 190.5mm diameter pitch circle (PCD). The sensor head should be mounted to the flue with at least four M16 or 5/8" bolts or studs spaced equally around the flange. The sensor head can be mounted to an existing 4" ANSI 150 flange, a weld-on ANSI flange (see Section 3.2.2) or to an existing flange of another type (see Section 3.2.3). Thermal spacers, high temperature stand-offs and probe retention flange options are also available for extreme environments. The length of the mounting bolts required will depend on the mounting options selected. For installation on an existing 4" ANSI flange provided with clearance rather than threaded holes then at least four M16x65mm or 5/8"x2½" bolts will be required. The sensor head will be provided with sufficient gaskets, M16 studding and M16 nuts and washers to mount the sensor head configuration supplied onto a Servomex weld on 4" flange.

3.2.2 Weld-on flange installation

If there is no existing flange available then a weld-on flange (part number 02750409) may be provided. The square (250mm x 250mm) weld-on flange is provided with 8 off M16 threaded holes at 45° intervals on a 190.5mm diameter pitch circle. Cut a hole 102mm (4 inches) to 127mm (5 inches) diameter in the wall of the duct and weld-on the flange. If no further mounting options have been ordered then screw the 4 off M16x55mm studs provided into alternate holes on the flange (at 90° intervals). Place the gasket over the locating studs, mount the sample probe onto the sensor head (see Section 3.3), and secure the sensor head onto the flange with the 4 off M16 nuts and washers.

3.2.3 Adaptor flange installation

A variety of adaptor flange kits are available (see Table 2) for fitting to flanges other than 4" ANSI 150. The flange on the process duct should be supplied with clearance holes appropriate to the flange type.

Refer to Figure 3.

Screw the flue mounting studs [8] and the four M16x55mm studs [7] into the appropriate threaded holes on the adaptor flange [3]. Ensure that the studs do not protrude through the flange as this will cause damage to the gasket/s and could cause leaks. Mount the adaptor flange [3] to the flue mounting flange [1] using the appropriate gasket [2] and secure with the nuts and washers [9] from the reverse. Attach the sample probe to the sensor head (see Section 3.3). Mount the 2700 sensor head [5] to the adaptor flange [3] using the 4" ANSI sealing gasket [4] and the 4 off M16 nuts and washers [6].

Table 2 – Sensor head adaptor flange kits				
Servomex Kit No.	Mating Pattern			Mates With
	Mtg.hole	Qty	PCD	
02750992	10.8 dia	8	120.6	Servomex Model 700B /N
02750991	M16	4	152.4	3" ANSI 150
02750991	M16	4	145.0	DIN 65 PN16
02750991	M16	4	145.0	JIS 80 5Kg/cm ²
02750990	M12	4	130.0	DIN 80 PN16
02750989	M12	4	130	JIS 65 5Kg/cm ²
02750988	M16	4	168.3	3" ANSI 300
02750991	18.0 dia c/bored 38.0 dia	3	168.3	Thermox WDG IV

Figure 3 Adaptor flange installation

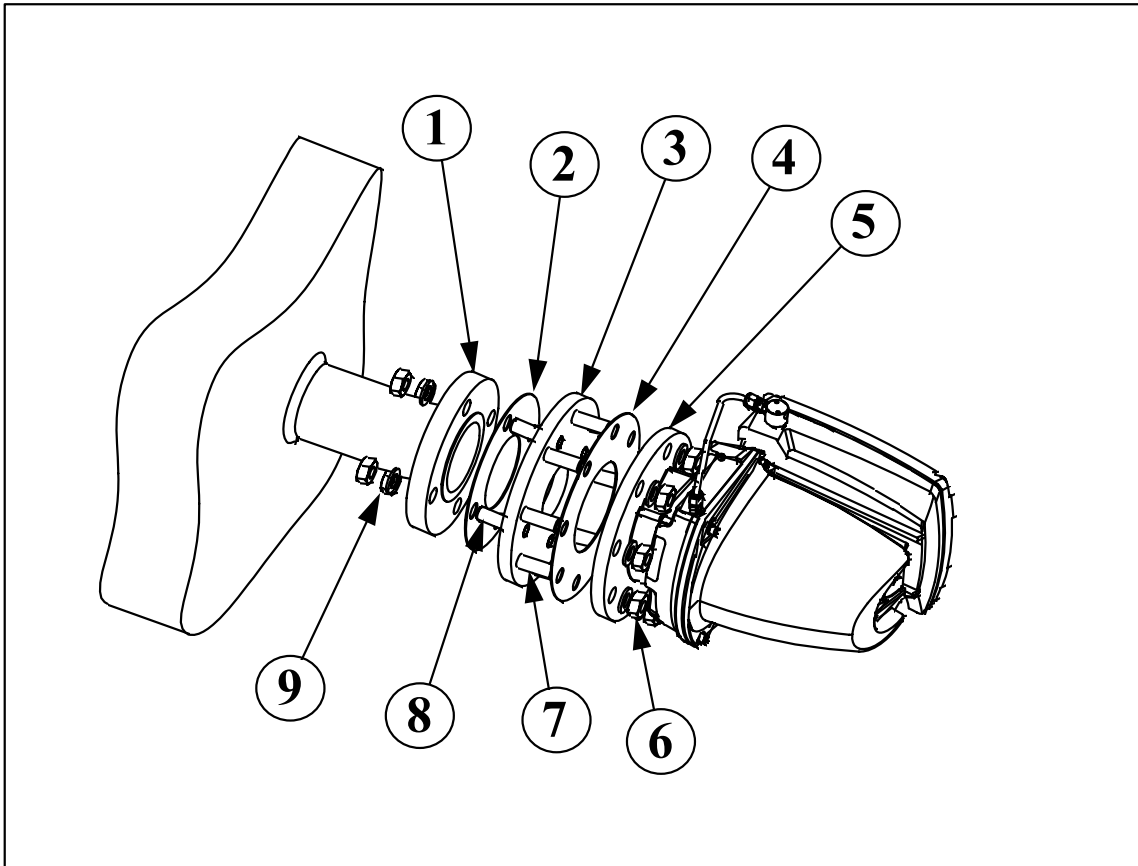

Key to Figure 3 – Adaptor flange installation

- 1 Mounting flange on flue
- 2 Gasket to suit flue mounting flange
- 3 Adaptor flange to suit flue mounting flange (see Table 2)
- 4 ANSI 4" gasket
- 5 4" flange on 2700 sensor head
- 6 M16 nuts and washers (4 off each)
- 7 M16 by 55mm studs (4 off)
- 8 Studs (type and length specific to flue mounting flange)
- 9 Nuts and washers (number and size to suit flue mounting flange)

3.2.4 High temperature stand-off installation

Where there may be excessive heat radiated from the flue wall (350°C to 500°C), a high temperature stand-off flange kit (part number 02750995) is available to prevent overheating of the sensor head. The high temperature stand-off is also available with a probe retention flange (part number 02750996). The high temperature stand-off consists of two 4" flanges welded onto a 102mm (4 inch) diameter pipe. Each of the flanges has four M16 threaded and four 19mm plain holes equally spaced on a 190.5mm diameter pitch circle (PCD).

Refer to Figure 4.

- Where necessary fit the weld-on flange or adaptor flanges as described in Sections 3.2.2 and 3.2.3.
- Mount the high temperature stand-off [3] onto the flue using a 4" ANSI sealing gasket [2]. If a 4" ANSI weld-on, or adaptor flange, is already fitted then screw in four of the M16x55mm studs [9] into alternate holes in the weld-on or adaptor flange [1] and attach the high temperature stand-off through the four plain holes in the stand-off flange. If the high temperature stand-off is to be attached to an existing 4" ANSI flange then use four M16x65mm (or 5/8"x2½") bolts at 90° intervals through the plain holes in the flange (bolts not supplied).
- If a probe retention flange is not required then mount the sample probe onto the sensor head (see Section 3.3). Mount the sensor head onto the high temperature stand-off using a 4" ANSI sealing gasket [4]. Screw the four M16x55 studs [7] into the threaded holes in the stand-off flange and secure the sensor head with the four M16 nuts and washers [6].
- If a probe retention flange is to be installed then screw the M16x80mm studs supplied into the threaded holes in the stand-off flange and install the probe retention flange as described in Section 3.2.6.

Figure 4 High temperature stand-off flange installation

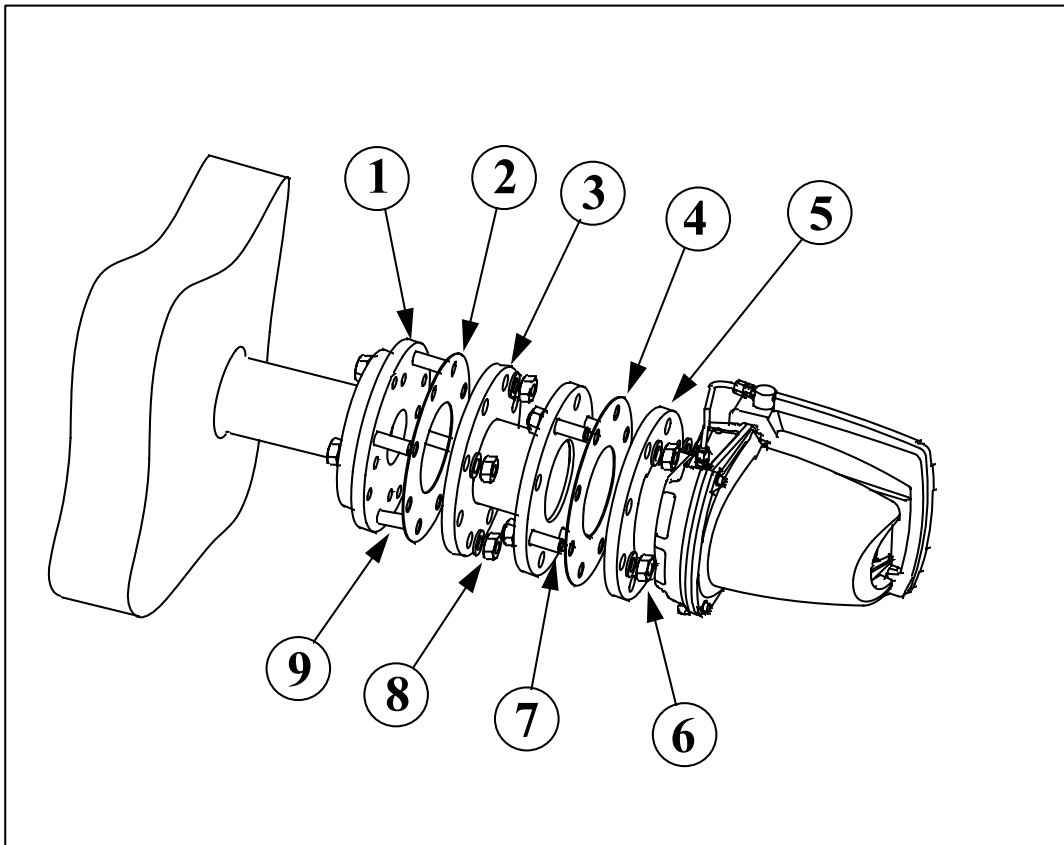

Key to Figure 4 – High temperature stand-off flange installation

- | | |
|---|--|
| 1 | 4" ANSI flange on flue with weld-on or adaptor flange fitted where necessary |
| 2 | ANSI 4" gasket |
| 3 | High temperature stand-off |
| 4 | ANSI 4" gasket |
| 5 | 4" flange on 2700 sensor head |
| 6 | M16 nuts and washers (4 off each) |
| 7 | M16 by 55mm studs (4 off) |
| 8 | M16 nuts and washers (4 off) |
| 9 | M16 by 55mm studs (4 off) |

3.2.5 Thermal spacer installation

When the flue surface temperature is between 350°C and 500°C, a thermal spacer (part number 02750997) is available to prevent overheating the sensor head. The thermal spacer is also available with a probe retention flange (part number 02750996). The spacer is provided with eight 19mm diameter holes equally spaced on a 190.5mm diameter pitch circle (PCD).

Refer to Figure 5.

- Where necessary fit the weld-on flange or adaptor flange as described in Sections 3.2.2 and 3.2.3.
- If a weld-on flange or adaptor flange has been fitted then screw the four M16x80mm studs [7] into alternate threaded holes in the flange. Mount the thermal spacer [3] with a 4" sealing gasket at each side [2 and 6]. Mount the sample probe onto the sensor head (see Section 3.3). Secure the sensor head flange [4] to the thermal spacer with the four M16 nuts and washers [5].
- If a weld-on or adaptor flange is not fitted then replace the four M16x80mm studs with M16x100mm or 5/8"x4" bolts (not supplied).
- Identify and mark the correct orientation of the retention flange so that the sample vent hole in the flange will align with the vent hole on the sensor head when installed in its desired orientation on the flue.
- If a probe retention flange is to be installed then replace the M16x80mm studs with the M16x105mm studs supplied. Install the probe retention flange as described in Section 3.2.6.

Figure 5 Thermal spacer installation

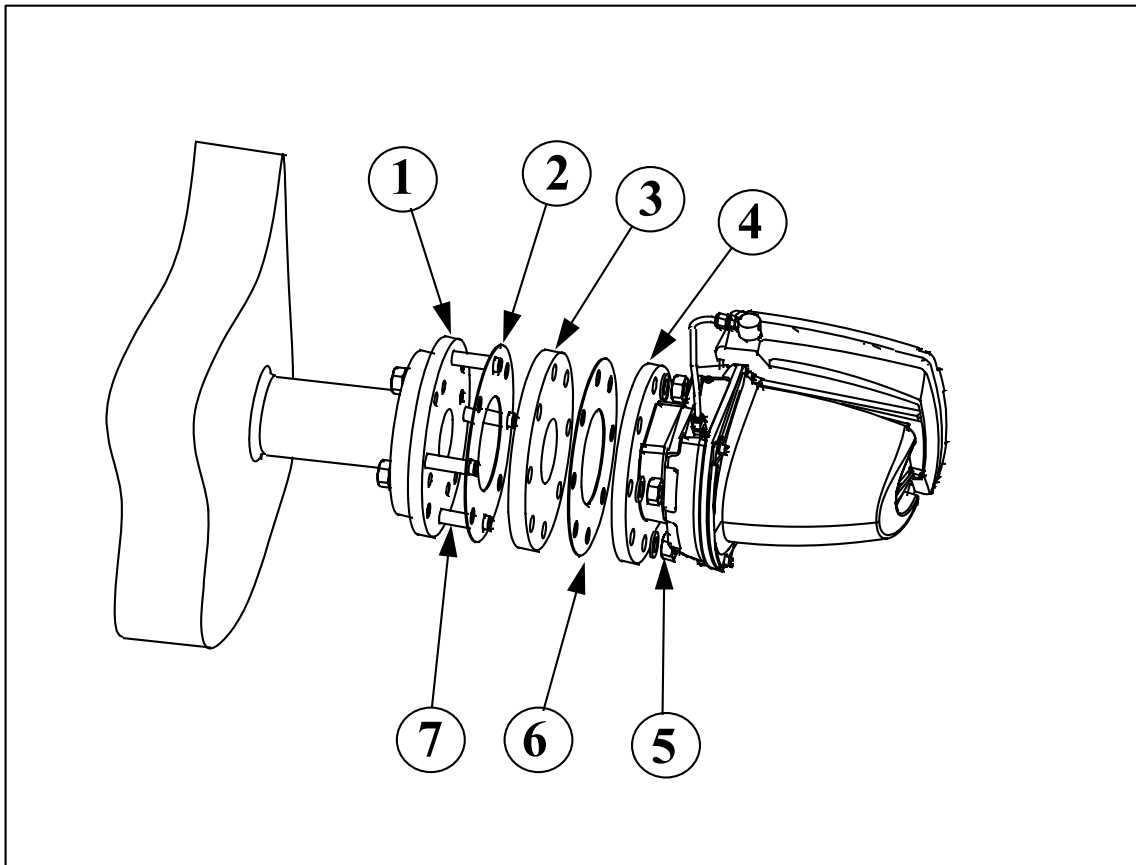

Key to Figure 5 – Thermal spacer installation

- | | |
|---|--|
| 1 | Mounting flange on flue. Adaptor flange fitted where necessary to provide 4" ANSI 150lb flange |
| 2 | ANSI 4" gasket |
| 3 | Insulation flange |
| 4 | 4" flange on Servomex 2700 sensor head |
| 5 | M16 nuts and washers (4 off each) |
| 6 | ANSI 4" gasket |
| 7 | M16 by 80mm studs (4 off) |

3.2.6 Probe retention flange installation

A probe retention flange (part number 02750998) is available when it is required to leave the probe in the process during servicing. This is useful when used in conjunction with a ceramic probe, so as to prevent the possibility of it being damaged during extraction. The probe retention flange is also available in conjunction with the thermal spacer and high temperature stand-off mounting options.

Refer to Figure 6.

- Where necessary fit the weld-on flange, adaptor flange, high temperature stand-off or thermal spacer as described in Sections 3.2.2, 3.2.3, 3.2.4 or 3.2.5.
- Identify and mark the correct orientation of the retention flange so that the sample vent hole in the flange will align with the vent hole on the sensor head when installed in its desired orientation on the flue.
- Attach the ceramic probe to the probe retention flange as detailed in Section 3.3.2.
- If the probe retention flange is being attached to a weld-on flange or adaptor flange [1] then screw the four M16x80mm studs [2] into alternate threaded holes in the weld-on or adaptor flange. Fit the 4" sealing gasket [4] over the protruding studs [2]. Then carefully insert the ceramic probe and retention flange through the hole in the centre of the flange/s and secure with the four M16 half nuts and washers [6]. If a weld-on or adaptor flange is not fitted then replace the four M16x80mm studs with M16x100mm bolts (not supplied).
- If the probe retention flange is being attached to a high temperature stand-off then insert the ceramic probe carefully through the hole in the high temperature stand-off and secure the probe retention flange onto the four M16x80mm studs with a 4" ANSI sealing gasket and the four M16 half nuts and washers.
- If the probe retention flange is being attached to a thermal spacer then insert the ceramic probe carefully through the hole in the thermal spacer and secure the probe retention flange onto the four M16x105mm studs with a 4" sealing gasket and the four M16 half nuts and washers.
- Mount the sensor head onto the protruding part of the mounting studs using the 4" ANSI sealing gasket [7] and the four M16 nuts and washers [8] provided. Ensure that the vent hole in the gasket and in the retention flange are aligned with the sample vent on the sensor head.

Figure 6 Probe retention flange installation

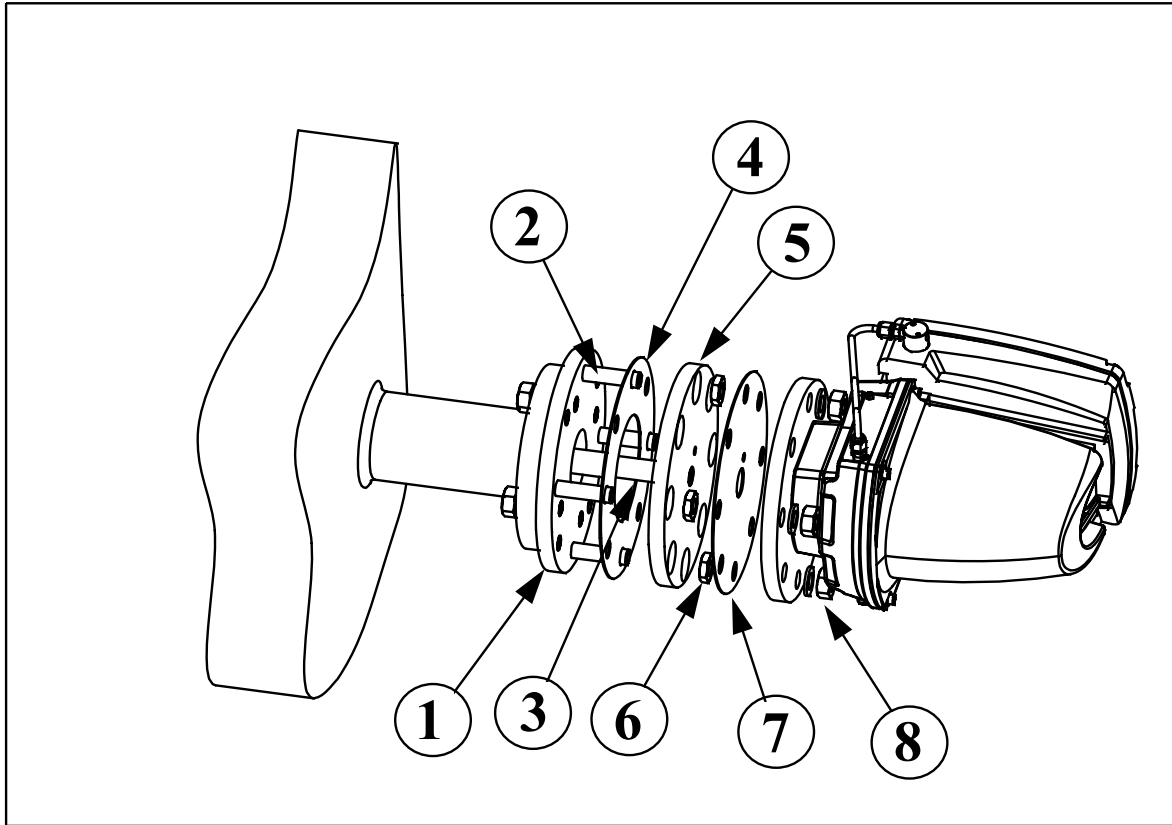

Key to Figure 6 – Probe retention flange installation

- 1 Adaptor flange
- 2 4 x M16x80mm studs
- 3 Ceramic probe
- 4 4" sealing gasket (large central hole)
- 5 Probe retention flange
- 6 4 x M16 half nuts and washers
- 7 4" ANSI sealing gasket
- 8 4 x M16 nuts and washers

3.3 Sample probe installation

CAUTION

If the flue is brick lined, ensure that the full diameter of the probe hole is maintained through the brickwork and is in line with the flange.

There are many possible configurations for the probe assemblies grouped into three main types:

- Open-ended sample probes (only use with internal sample filter option).
- Unsupported filtered sample probes.
- Supported filtered sample probes.

Table 3 contains a list of the different sample probes available and their part numbers. The installation of the different sample probe types is detailed in the following sections.

3.3.1 Open-ended and unsupported filtered metal probe installation

The open-ended and unsupported filter probes are available in 4 different lengths and 2 different materials depending on process conditions and flue temperature. Refer to Figure 7 for construction of the filter probe.

- Cut the probe tube to length if required. The cut should be square and any burrs and swarf should be removed.
- Fit the tube coupling to the sensor head sealing the thread with PTFE tape.
- Fit the probe tube into the coupling until the probe tube bottoms out in the sensor head. Swage the coupling ferrule onto the tube by tightening the coupling finger tight plus a further 3/4 to 1 turn.
- Insert the probe carefully through the hole in the flange gasket and attach the sensor head onto the flue. Ensure that the mounting bolts are tightened evenly.

3.3.2 Open-ended ceramic probe installation

The open-ended ceramic probe is available in three different lengths. The probe is supplied complete with a 1/2" NPT threaded stainless steel fitting bonded to the end of the ceramic tube. The ceramic probe may be attached directly to the sensor head (using PTFE tape to seal the thread) or to a probe retention flange. The probe retention flange is used to avoid potential damage to the fragile probe when removing the sensor head from the flue for maintenance purposes. Refer to Section 3.2.6 for probe retention flange installation.

Table 3 – Sample probe part numbers					
0.5m	1.0m	1.5m	2.0m	2.5m	3.0m
Open-ended, Stainless Steel, <700°C					
S2740701A	S2740701B	S2740701C	NA	NA	NA
Open-ended, High temperature alloy, <1000°C					
S2740704A	S2740704B	NA	NA	NA	NA
Open-ended, High temperature alloy, <800°C					
S2740704A	S2740704B	S2740704C	NA	NA	NA
Open-ended, High temperature alloy, <700°C					
S2740704A	S2740704B	S2740704C	S2740704D	NA	NA
Filtered, Stainless Steel, <700°C					
S2740702A	S2740702B	S2740702C	NA	NA	NA
Filtered, High temperature alloy, <1000°C					
S2740705A	S2740705B	NA	NA	NA	NA
Supported filtered, Stainless Steel, <700°C					
NA	NA	S2740703C	S2740703D	S2740703E	S2740703F
Open-ended ceramic, <1750°C					
02740707A	02740707B	02740707C	NA	NA	NA

Figure 7 Sample probe and filter construction

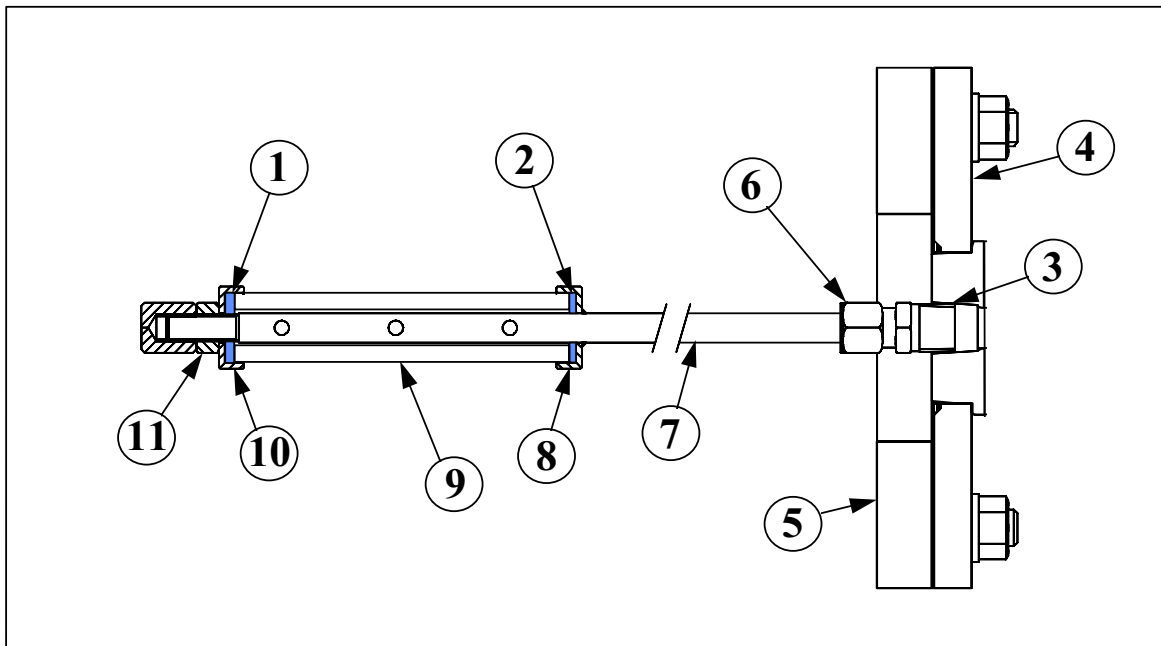

Key to Figure 7 – Sample probe and filter construction

1	Fibre sealing washer
2	Fibre sealing washer
3	½" NPT threaded mounting hole in Servomex 2700 filter block
4	2700 mounting flange
5	Mounting flange on flue
6	½" compression to ½" NPT adaptor
7	Probe tube
8	Filter retaining cap
9	Silicon carbide filter element
10	Filter retaining cap
11	Locking nut assembly

Figure 8 Supported probe construction

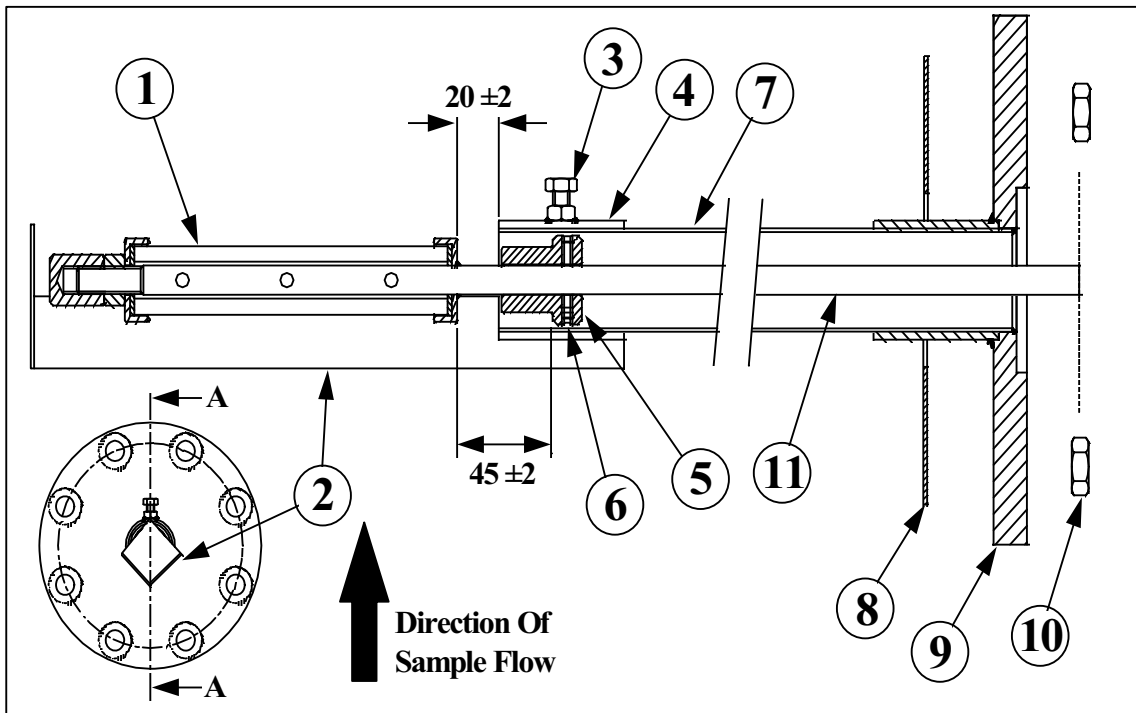

Key to Figure 8 – Supported probe construction

- 1 Silicon carbide sample filter
- 2 Sample filter shroud (V deflector)
- 3 Sample filter shroud M8x18mm fixing screw
- 4 Sample filter shroud collar
- 5 Sample probe retaining disc
- 6 Sample probe retaining disc M5x10mm fixing screws (2 off)
- 7 Support tube
- 8 4" sealing gasket
- 9 Support tube flange
- 10 4 x M16 nuts and washers
- 11 Sample probe tube

3.3.3 Supported probe installation

The supported probe assembly are supplied in a range of lengths from 1.5m to 3.0m in 0.5m steps. The installation process may be divided into three parts.

Cutting the probe and support tubes to length

- The probes are provided cut to the correct lengths for the nominal specified insertion depth. To shorten the probe assembly cut equal lengths from both the support tube and the probe tube. The cuts should be square and any burrs and swarf removed.

Installing the support tube assembly

- Refer to Figure 8. Fit the sample filter shroud [2] onto the end of the support tube [7]. The sample filter shroud [2] must be positioned with respect to the direction of the sample flow as shown in Figure 8. The end of the sample filter shroud collar [4] must be flush with the end of the support tube [7]. The M8x18mm hex head shroud fixing screw [3] should then be tightened to securely locate the sample filter shroud [2] in position. Mark the support tube flange [9] to identify the orientation of the shroud and the direction of the sample flow.
- Refer to Figure 9. Where necessary fit the weld-on flange or adaptor flange, as described in Sections 3.2.2 or 3.2.3. If the support tube flange is being attached to a weld-on flange or adaptor flange then screw the four M16x80mm studs into alternate threaded holes in the weld-on or adaptor flange. Secure the support tube flange with a 4" sealing gasket and the four M16 half nuts and washers. If a weld-on or adaptor flange is not fitted then replace the four M16x80mm studs with M16x100mm bolts (not supplied). Ensure the filter shroud orientation is correct with respect to the direction of sample flow in the process.

Installing the filter probe assembly

- Refer to Figure 8. Fit the probe retaining disc [5] onto the sample probe tube [11]. Fix in position using the two M5x10mm grub screws [6]. The front face of the disc should be positioned approximately 20mm from the back face of the filter assembly.
- Fit the tube coupling to the sensor head sealing the thread with PTFE tape.
- Fit the probe tube into the coupling until the probe tube bottoms out in the sensor head. Swage the coupling ferrule onto the tube by tightening the coupling finger tight plus a further 3/4 to 1 turn. Release the union nut from the fitting in the sensor head.
- Insert the sample probe into the probe support tube. Taking care to leave at least 100mm protruding from the flange to allow attachment to the sensor head.
- Fit a 4" sealing gasket [7] over the protruding studs from the support tube flange.
- Attach the sensor head to the protruding length of the sample probe tube using the compression fitting. Attach the sensor head to the support tube flange and secure in place with the four M16 nuts and washers [8].

Figure 9 Probe support tube installation

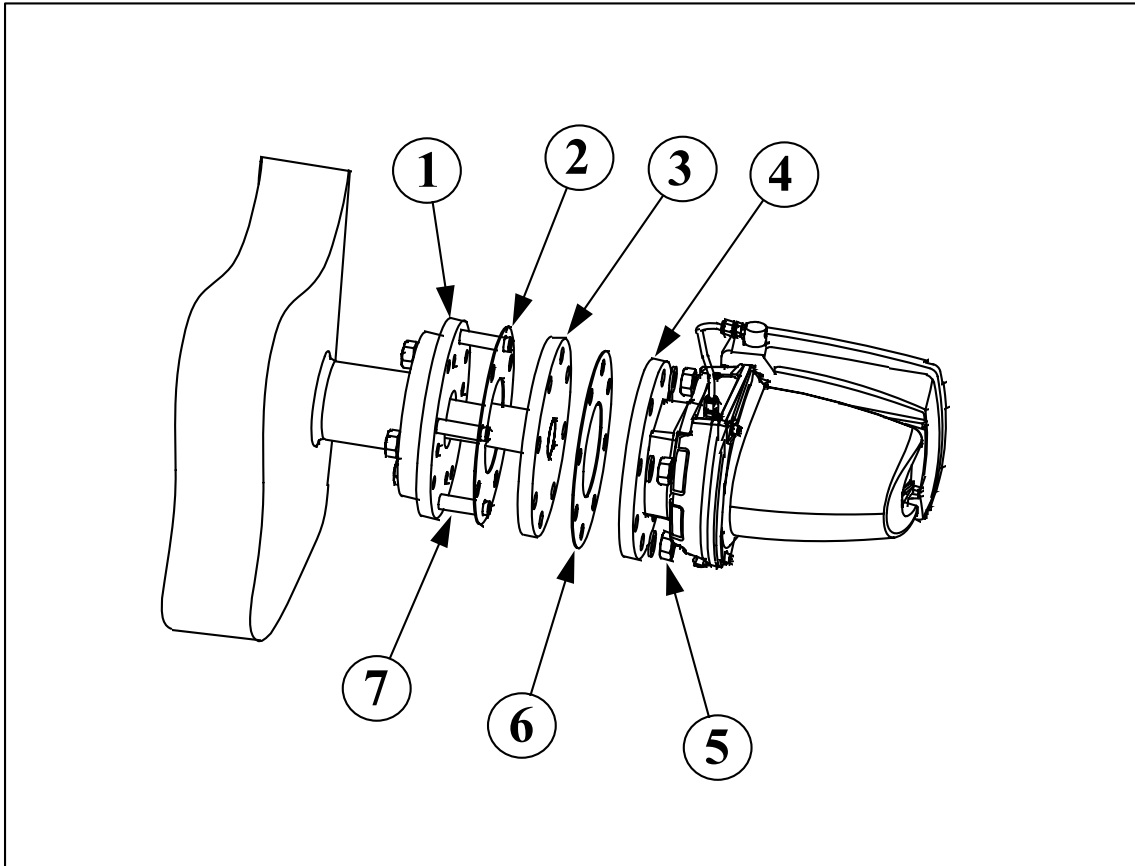

Key to Figure 9 – Probe support tube installation

- 1 Mounting flange on flue. Adaptor flange fitted where necessary to provide 4" ANSI 150 lb flange.
- 2 ANSI 4" gasket
- 3 Support tube flange
- 4 4" flange on 2700 sensor head
- 5 M16 nuts and washers (4 off each)
- 6 ANSI 4" gasket
- 7 M16 by 80mm studs

3.4 Calibration and utilities supplies

Refer to Figure 2.

WARNING

The maximum pressure that should be applied to any of the Servomex 2700 analyser inlet ports is 1 bar (max).

A number of calibration and utilities gas supplies are required by the sensor head depending on the sensor configuration used. For optimum performance, only one analyser should be used in conjunction with an air supply or utilities unit.

All pressure regulators, flow meters and gauges exhibit variations of output with changes in ambient temperature. Care should be taken to choose products with either a good rejection to changes in ambient temperature or to install air supply units in stable ambient conditions.

- Aspirator supply* The aspirator air supply is used to extract the sample from the flue and is required for all sensor head configurations. This is an instrument grade compressed air supply provided to a 1/8" NPT (internal) threaded port (item 10) on the solenoid valve body. The compressed air supply should be clean, dry, free from oil and dirt ideally conforming to ISA-S7.0.01 1996. The aspirator pressure range required is 3 to 5psig (0.2 to 0.3barg). The flow rate is typically 1.5l/min under typical flue pressure conditions.
- Calibration gas* Required for all sensor head configurations. Calibration gas is supplied to the sensor head via a 1/4" OD compression fitting (item 4).
The calibration gas supply pressure should be regulated externally to give a flow rate to the port of 600ml/min \pm 20ml/min.
- Purge supply* Optional feature. Where required, the purge gas must be air from a non-hazardous area source. The purge air fittings are threaded 1/4" NPT (internal). The purge inlet is to the terminal box (item 7) and the vent is on the sensor head body (item 5). The supply should be clean, dry, free from oil and dirt ideally conforming to ISA-S7.0.01-1996 and the pressure should be regulated externally.
For hazardous Areas, the purge must satisfy the area safety requirements.
For corrosive purge, a flow rate of 50 to 100ml/min at 50 to 100mm H₂O is required.

CAUTION

If the optional sensor head purge fittings are used then ensure that the purge gas entry and vent fittings are the correct way round. Providing the purge gas inlet to the sensor head body rather than the terminal box will result in overheating of the terminal box PCB.

Blowback

Should be supplied at a pressure no greater than 15psig (105kPag).

Blow back must not be used instead of a suitably specified sample probe. If you have any concerns over the included probe, consult Servomex prior to installation.

Auto Calibration

Time must be given to allow for calibration pipe work to be flushed and for the sensors to stabilise. This depends on the separation between gas supply point and the Sensor Head.

3.5 Electrical installation

WARNINGS

Refer to the warnings and conditions outlined in the "General safety information" in Section 1.3 of this manual.

CAUTION

- The sensor head supply voltage is factory set for either 100-120V or 220-240V (nominal). This is not field adjustable.
- Ensure that the rated voltage is suitable for the installation.
- Ensure that the link on the terminal PCB has been set to the correct supply voltage. Refer to Figure 10. The supply voltage is set by linking together the terminals at terminal block TB9. For 220-240V operation link together terminals TB9/2 and TB9/1. For 110-120V operation link together terminals TB9/2 and TB9/3. For 100V operation link together terminals TB9/2 and TB9/4.
- Use wires suitable for 30°C above surrounding ambient.
- The sensor head is intended to be powered from a supply which has the 'Neutral' conductor referenced to ground. Where this is unavailable, it is recommended that a suitable isolating transformer is installed and the secondary winding is referenced to ground.

Alternatively, the electrical installation must include a fuse rated "F 6.3A HRC" in each supply conductor. The disconnect device (see also Section 1.3) must disconnect each supply conductor. The fuses must be marked as being associated with this equipment. Ensure that the installation conforms to the relevant national and local safety requirements.

NOTES

- The sensor head and control unit have independent electrical supplies.
- If applicable the conduit or screen associated with the power supply should be grounded at the cable gland or conduit entry to the sensor head terminal enclosure in accordance with local wiring regulations.
- In order to avoid ground loops, it is recommended that cable screens associated with the signal cable(s) connecting the control unit and sensor head do not terminate directly to ground at the sensor head. The screens should be terminated to TB5/13, TB3/9 and the stud PCB terminal – S, as detailed on the interconnection diagram and Figure 10.
- Fuse F1 located in the terminal box is rated F6.3A HRC for both 100-120V and 220-240V operation.

WARNING

The sensor head and control unit have independent electrical supplies. This means that if the sensor head is unpowered, the COe sensor may still be heated to 300°C by the control unit. If the control unit is unpowered, the sensor head will still be heated to 250°C by its own power supply.

- Refer to Appendix A for an interconnecting wiring schedule for the sensor head. See also the wiring diagrams in Figures 13, 14 and 15.
- Electrical terminations are suitable for 20 AWG (0.5mm²) to 14 AWG (2.5mm²) solid conductors or 16 AWG (1.5mm²) stranded conductors.
- Gland entry sizes and positions are shown in Figure 2. Unused entries should be fitted with appropriate blanking plugs.
- Ensure that good EMC practices are observed when making connections.
- All electrical connections and access to the fuse, F1, are made to the terminal PCB inside of the terminal box enclosure. Refer to Figure 2. To gain access unscrew the four M6 [11] screws using a 5mm allen key and remove the terminal box cover. After electrical connections are complete ensure the cover is fully bolted down.

Table 4 – Sensor head electrical power connections

		Terminal
Electrical power 100-120Vac or 220-240Vac 50/60Hz, 600VA maximum	Live	TB1-L
	Neutral	TB1-N
	Protective earth	TB1-Protective ground

Note that terminal TB1-protective ground is at the right-hand side

Figure 10 Sensor head terminal enclosure detail

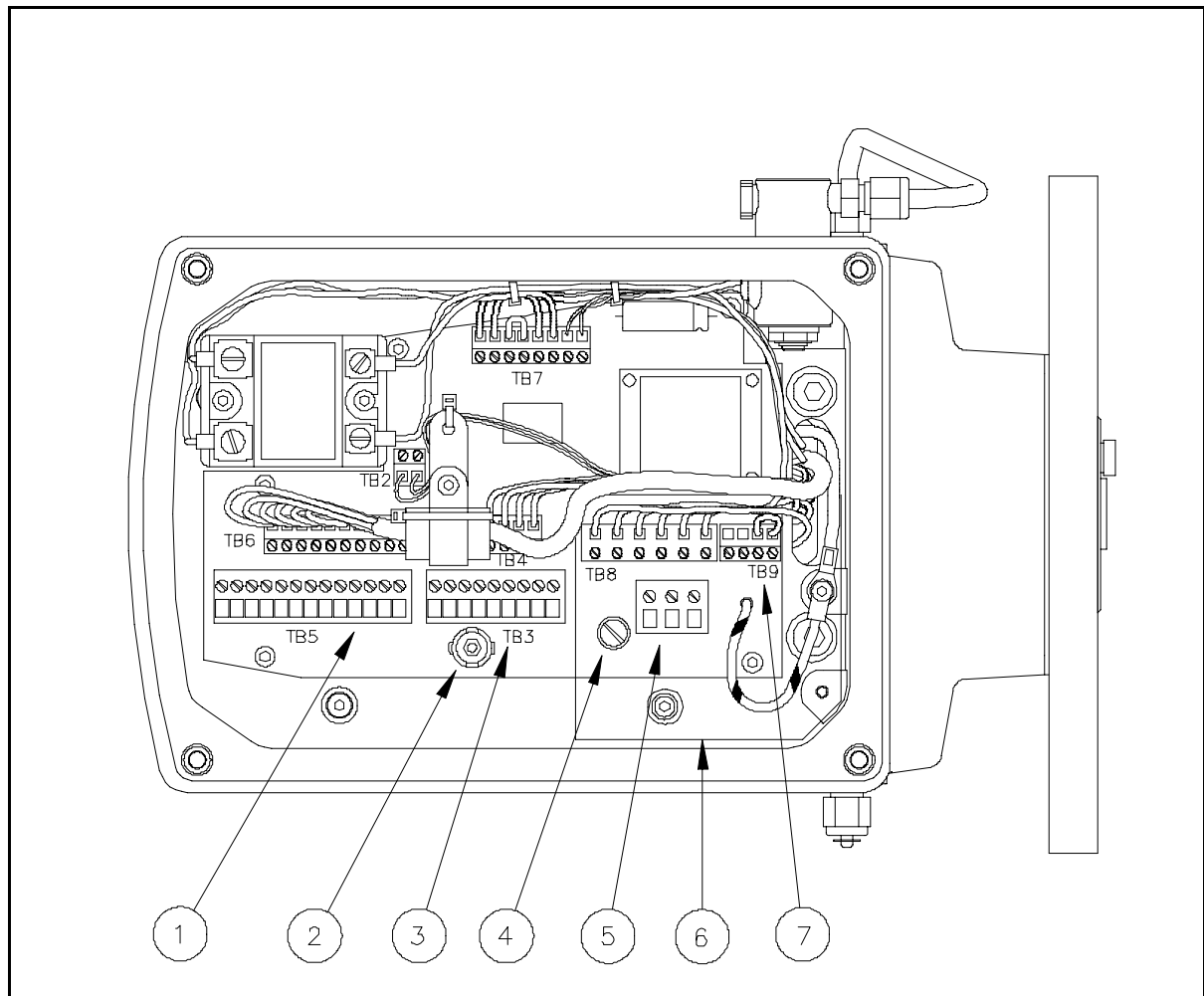

Key to Figure 10 – Sensor head terminal enclosure detail

- 1 Terminal block TB5 (combustibles sensor wiring)
Pin 1 at right-hand side
- 2 Stud terminal – S
- 3 Terminal block TB3 (oxygen and sensor head temperature wiring)
Pin 1 at right-hand side
- 4 Fuse F1
- 5 Terminal block TB1 (main power wiring)
- 6 Plastic safety cover
- 7 Terminal block TB9 (mains voltage selection)
Pin 1 at right-hand side

CAUTION

After installation, the Sensor Head should not be left on the flue unpowered for extended periods, as condensation may form within the sample pipe work. The Sensor Head should be removed from the process and protected against external contamination, or left with 600ml/min of instrument air flowing through the calibration port, until the analyser can be fully commissioned and placed online.

This page is intentionally blank

4 INSTALLATION OF CONTROL UNIT

4.1 Installation location

Refer to Figure 11.

Servomex 2700 Control Units and air supplies (utilities units) should, ideally, be mounted within easy reach of one another to aid routine calibration. They should also be mounted as close as possible to the Sensor Head to minimise the analyser's response time to calibration gases, to help maintain the stability of the air supply units and to minimise the effects of pressure drops.

Select a location which allows convenient access for installation, maintenance and will minimise ambient temperature fluctuations and vibration. The control unit should be mounted horizontally with the electrical entries on the under side. The operating environment conditions for the control unit are in Table 5.

Ensure the ambient temperature does not exceed specification. The control unit and display may require protection from direct sunlight and local radiant heat sources. This can be achieved by the installation of a heat shield between the control unit and the heat source; a thin metal sheet is usually adequate.

The Servomex 2710 Control Unit is essentially an aluminium enclosure finished with a protective epoxy powder paint. A polycarbonate window facilitates viewing the integral display and the user interface is via a polyester keypad. All weatherproof seals are silicone rubber.

WARNING

If the control unit is to be installed in an area which may be hazardous due to the presence of flammable gases or dusts then any "Special Conditions for Safe Use" and/or "Schedules of Limitation", as detailed in the Safety Certification, must be followed.

NOTES

Allow 365mm at the front and 250mm to the left hand side for service access.

The control unit may be mounted either to a rigid vertical surface (wall mounted) capable of supporting the weight of the enclosure or panel mounted.

For the wall mounting option two metal mounting brackets are fitted to the rear of the control unit using four M8 by 20mm screws and washers. Four 12mm diameter holes are provided for mounting the control unit to the wall. Servomex recommend the use of M8 or 3/8" bolts to fix the control unit to the wall.

For the panel mounting option the control unit is inserted through the large hole in the mounting bracket and secured using four M8 by 20mm screws and washers. The size of the mounting panel is designed to fit standard 19" rack mounting systems. The mounting panel is provided with eight 6.5mm slots for attachment to the rack or panel.

Table 5 – Control unit operating environment

Item	Specification
Ambient operating temperature	-10°C to +55°C (+14°F to +131°F)
Storage temperature	-20°C to +55°C (-4°F to +131°F)
Ingress protection	IP66 and NEMA 4X
AC power supply. Two user-selectable voltage ranges: a) 100-120Vac 50/60Hz b) 220-240Vac 50/60Hz	a) 100-120Vac -15% +10% (Min. 85V – Max. 132V) b) 220-240Vac -15% +10% (Min. 187V – Max. 264V)
Altitude	Up to 2000m
Installation category	Installation Category II. Local level power distribution with over-voltage withstand up to 2500V (in accordance with IEC 664).
Pollution degree	Pollution Degree 2 (in accordance with IEC 664). <i>See Note 1</i>
Relative humidity	0 to 80% RH
<p><i>Note 1:</i> Where the installation is such that the enclosure ingress protection IP66/Type 4X is maintained and the covers remain securely fitted, the apparatus is suitable for use in locations where there may be significant deposits of nonflammable dusts or fibres (Pollution Degree 4) and/or where there may be drips, splashes of water, prolonged exposure to rain or subjected to hose down.</p> <p>The covers may be removed during installation or servicing only if there is negligible risk of pollution or contamination of the electronic circuits contained within the enclosures and if the covers are securely replaced immediately after the operation is completed. Refer to Section 6.</p>	

Figure 11 Control unit installation

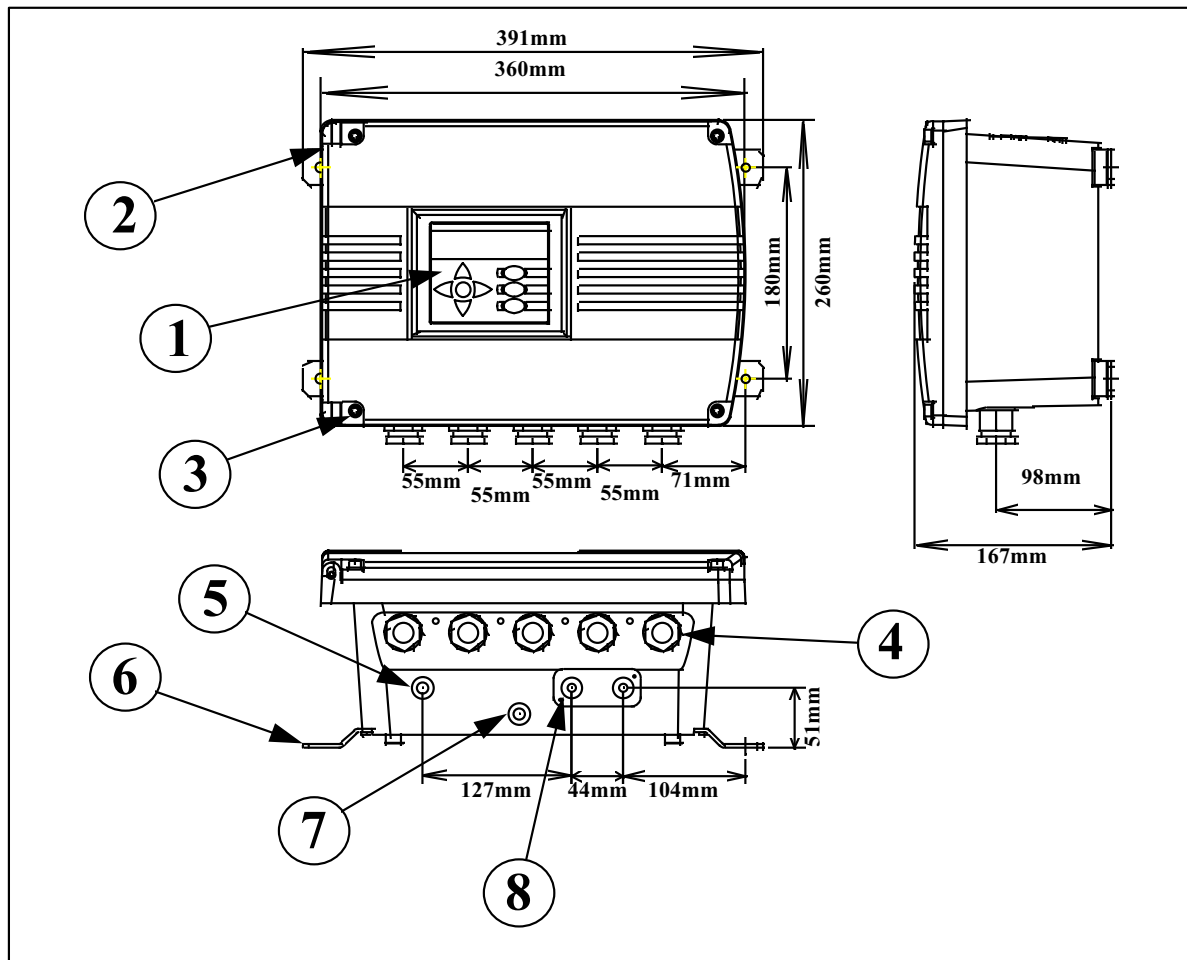

Key to Figure 11 – Control unit installation

- 1 Keypad and LCD display
- 2 Door hinge
- 3 M6 bolts (4 off)
- 4 3/4" NPT (INT) threaded cable conduit entries or optional adaptors as required
- 5 Enclosure breather fitting (optional) or blanking port
- 6 Wall mounting brackets (optional)
- 7 EMC earth terminal
- 8 1/4" NPT (INT) threaded enclosure purge inlet and outlet fittings (optional) or blanking plugs

4.2 Electrical installation

WARNINGS

- Refer to the warnings and conditions outlined in the "General safety information" in Section 1.3 of this manual.
- The sensor head and control unit have independent electrical supplies. This means that if the sensor head is un-powered, the COe sensor may still be heated to 300°C by the control unit. If the control unit is un-powered, the sensor head will still be heated to 250°C by its own power supply.

CAUTION

The control unit is intended to be powered from a supply which has the 'Neutral' conductor referenced to ground.

Where this is unavailable, it is recommended that a suitable isolating transformer is installed and the secondary winding is referenced to ground.

The electrical installation must include a fuse (rated as specified in Table 6) in each supply conductor. The disconnect device (see also Section 1.3) must disconnect each supply conductor. The fuses must be marked as being associated with this equipment. Ensure that the installation conforms to the relevant national and local safety requirements.

NOTES

- If applicable the conduit or screen associated with the power supply should be grounded at the cable gland or conduit entry to the control unit enclosure in accordance with local wiring regulations.
- The Servomex 2700 is rated in accordance with IEC 644 for INSTALLATION CATEGORY II which is characterised as being local level (not distribution level), appliances and portable equipment with over-voltage impulse withstand up to 2500V.
- Electrical terminations are suitable for 20 AWG (0.5mm²) to 14 AWG (2.5mm²) solid conductors or 16 AWG (1.5mm²) stranded conductors.
- Gland entry sizes and positions are shown in Figure 11. Unused entries should be fitted with appropriate blanking plugs.
- Do not exceed the maximum load impedance of 1000 ohms for the analogue (0/4-20mA) current outputs.

- Electrical power should be supplied at 100-120V or 220-240V (+10% -15%) 50/60 Hz. To gain access refer to Figure 11. Unscrew the four M6 bolts [3] using a 5mm Allen key and open the control unit door. Ensure that the transformer primary connection (PL6 or PL7 in Figure 12) and the main power fuse rating (F1) are appropriate for the electrical supply voltage (see Table 6).

Table 6 – Control unit electrical power voltage selection		
Nominal voltage	Transformer primary connection	Mains power fuse (F1) rating
100-120Vac	PL7	T3.15A HRC
220-240Vac	PL6	T1.6A HRC

- For compliance with the EMC standards, the control unit enclosure must be connected to a local EMC earth. Signal cable connections to the control unit must be made using screened or shielded cable with the screens terminated to the control unit enclosure. The recommended method is to terminate the screen or shield at the cable gland. Where this is impractical, the screen or shield may be terminated inside the enclosure, using the M4 studs adjacent to the cable entries. Ensure that good EMC practices are observed when making connections.
- All electrical connections and access to the mains power fuse, F1, are made to the control PCB inside of the control unit enclosure. After electrical connections are complete ensure that the safety cover is re-fitted and the access door is fully bolted down.

Figure 12 Control unit enclosure detail

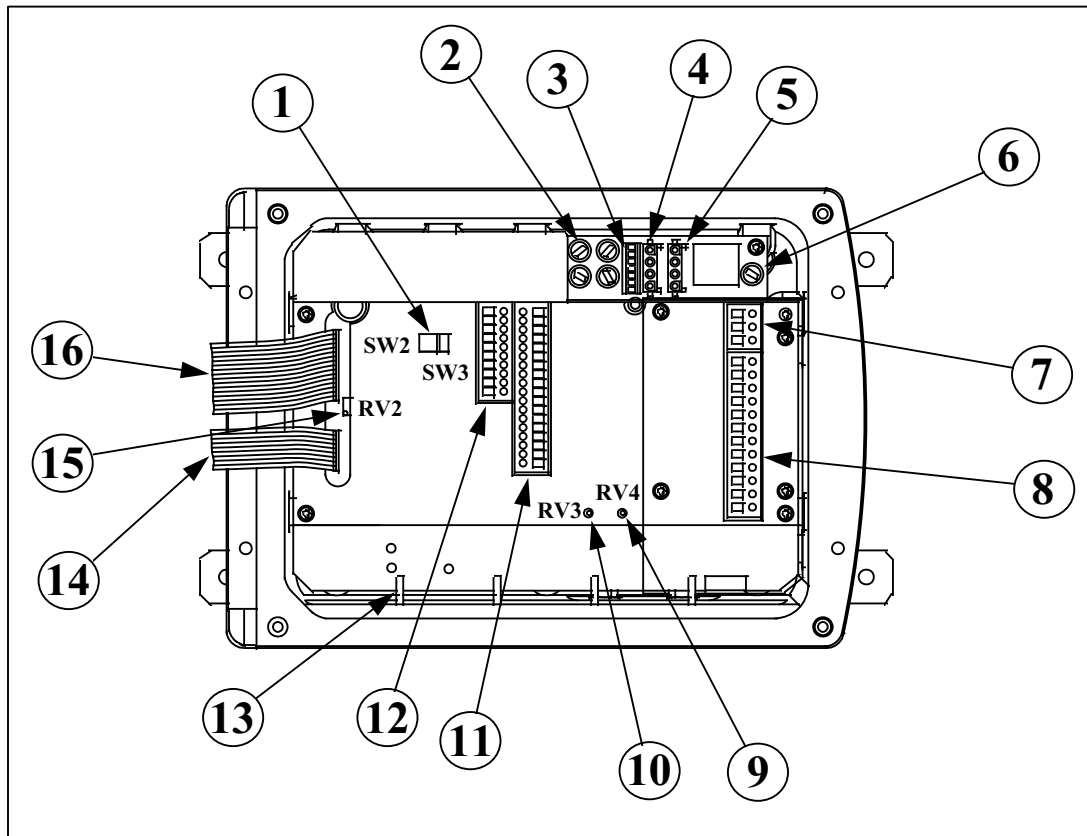

Key to Figure 12 – Control unit enclosure detail

- 1 Tfx sensor coarse zero adjustments SW2 (left) and SW3 (right)
- 2 Sensor heater fuses F2 to F5
- 3 Transformer secondary connection PL5
- 4 Transformer primary connection PL6 (220-240V nominal)
- 5 Transformer primary connection PL7 (100-120V nominal)
- 6 Mains power fuse F1
- 7 Mains power connections TB3
- 8 Relay output connections TB4
- 9 (0/4-20mA) Analogue output span adjustment for oxygen sensor RV4
- 10 (0/4-20mA) Analogue output span adjustment for combustibles sensor RV3
- 11 Terminal block TB2 interconnection wiring and external signal connections
- 12 Terminal block TB1 interconnection wiring
- 13 M4 cable screen termination studs (4 studs)
- 14 Keypad ribbon cable connection PL2
- 15 LCD viewing angle adjustment RV2
- 16 LCD ribbon cable connection PL1

Electrical power and user external connections to the analyser outputs are detailed in Figures 13, 14 and 15 and in Tables 7, 8, 9 and 10. Interconnecting wiring between the control unit and the sensor head is detailed in Appendix A.

CAUTION

Connections to terminal block TB2-15, 16, 17 and 18 (analogue output signal terminals) should not exceed 30V RMS (42.4V peak) or 60V dc to earth when connected to associated equipment.

4.3 Enclosure purge connection

A purge may be applied to the control unit to help prevent corrosion within the enclosure.

The enclosure purge inlet and outlet connection sizes and location are shown in Figure 11.

The purge gas must be air from a non-hazardous area source or an inert gas. The control unit internal volume is approximately $8.5 \times 10^{-3} \text{m}^3$ (520in³). Vent the outlet freely to atmosphere and ensure that the vent cannot become blocked or restricted.

For hazardous Areas, the purge must satisfy the area safety requirements.

For corrosive purge, a flow rate of 50 to 100ml/min at 50 to 100mm H₂O is required.

Table 7 – Control unit electrical power connections		
		Terminal
Electrical power 100 to 120Vac -15% +10% 220 to 240Vac -15% +10% 50/60Hz, 250VA maximum	Live Neutral Protective earth	TB3-L TB3-N TB3-Protective ground
Note that pin TB3-protective ground is at the top		

Table 8 – Relay output connections		
		Terminal
Relay 1 250Vac, 3A 28V dc, 1A	Closes on relay 1 set and opens on power fail Opens on relay 1 set and closes on power fail Common	TB4-1 TB4-2 TB4-3
Relay 2 250Vac, 3A 28V dc, 1A	Closes on relay 2 set and opens on power fail Opens on relay 2 set and closes on power fail Common	TB4-4 TB4-5 TB4-6
Relay 3 250Vac, 3A 28V dc, 1A	Closes on relay 3 set and opens on power fail Opens on relay 3 set and closes on power fail Common	TB4-7 TB4-8 TB4-9
Relay 4 250Vac, 3A 28V dc, 1A	Closes on relay 4 set and opens on power fail Opens on relay 4 set and closes on power fail Common	TB4-10 TB4-11 TB4-12
Note that TB4-12 is at the top		
The relay outputs may be configured by the user to be either concentration alarms, fault indications, autocalibration or blowback valve drives via the analyser software interface. Minimum 10mA 5V AC or DC. Maximum 3A/250Vac 1A/28Vdc.		

Table 9 – Analogue output connections		
		Terminal
0/4 to 20mA oxygen output signal (isolated) maximum load impedance 1000 ohms	+ ve	TB2-15
	- ve	TB2-16
0/4 to 20mA combustibles output signal (isolated) maximum load impedance 1000 ohms	+ ve	TB2-17
	- ve	TB2-18
The full scale of the above outputs represents the range selected by the user via the analyser software interface.		

Table 10 – User remote dry contact inputs		
		Terminal
Close contacts to initiate an automatic calibration of the analyser	+ ve	TB2-11
	ground	TB2-12
Close contacts to initiate an automatic blowback of the analyser	+ ve	TB2-13
	ground	TB2-14
The remote dry contacts must be suitable for use with the low voltage signal generated by the control unit, i.e. 5V 50µA maximum.		
Calibration and blowback parameters to be set by the user via the software interface prior to remote function initiation.		

This page is intentionally blank

5 INITIAL STARTUP PROCEDURE

WARNING

Carbon monoxide is a toxic gas. When sampling gases containing carbon monoxide ensure that adequate precautions are taken to ensure that any vented gases are suitably extracted.

5.1 Gases required

The gas samples required to commission and calibrate the analyser depend on the configuration of the analyser. Refer to Table 11.

Table 11 – Gas requirements						
Service	Gas	Press. psig	Flow l/min	O ₂	COe	Dual
Aspirator supply	Regulated clean dry air	3-5	typically 1.5	yes	yes	yes
Calibration gas for O ₂ 'HIGH CAL' and COe 'LOW CAL'	Regulated clean dry air	0-15	0.6 to 0.8	yes	yes	yes
Calibration gas for O ₂ 'LOW CAL'	0.3% O ₂ balance N ₂ *	0-15	0.6 to 0.8	yes	no	yes
Calibration gas for COe 'HIGH CAL'	1000ppm(v) CO balance air **	0-15	0.6 to 0.8	no	yes	yes

*calibration gas composition can be between 0.25% and 2.5% O₂ in N₂

** calibration gas composition can be between 500ppm(v) to 1,000ppm(v) for a 1750702 sensor and 1,000ppm(v) to 2,000ppm(v) in air for a 1750703 sensor.

5.2 Visual inspection

Check the rating label on the sensor head terminal box lid to ensure that the voltage and frequency stated are suitable for the installation.

In the sensor head terminal box (refer to Figure 10):

- Check voltage selection link is set to the appropriate supply voltage (see Section 3.5).
- Check fuse F1 fitted is F6.3A HRC (voltage independent).

In the control unit (refer to Figure 12):

- Check that the transformer primary lead is connected to the correct socket. PL7 for 100V-120V (nominal) or PL6 for 220V-240V (nominal).
- Check that the fuse F1 fitted is T3.15A HRC for 100-120V (nominal) or T1.6A HRC for 220-240V (nominal).

Interconnecting wiring:

- Check that all interconnections are correctly wired and terminated in accordance with local electrical safety requirements and the interconnection wiring schedules in Appendix A.

5.3 Initial power up

Connect the sensor head and control units to the nominal required power supply.

Refer to Figure 12. Adjust RV2 on the control unit PCB (viewing angle adjustment for the LCD display) to give the best display contrast when viewed under normal conditions.

NOTE

The LCD display may appear completely blank if this control is incorrectly adjusted.

From a cold start, the sensor head will pre-heat the air space, depending on configuration and ambient temperature before applying power to the individual sensor heaters. The aspirator air supply is controlled by a solenoid valve. The solenoid valve will remain closed until the sensor head is at operating temperature. This will prevent inadvertent damage to the sensor head by exposing it to sample gases before the internal temperature is above the sample gas dew point. The solenoid valve will operate after a time interval of between 15 and 60 minutes depending on configuration and ambient temperature.

Wait until both the sensor head and control unit have both been switched on for a minimum of 90 minutes. Refer to Figure 11 and perform the following tests.

- Using the control unit keypad select the VIEW menu entry then scroll using the up and down arrow keys until the oxygen sensor temperature is displayed. Check that the oxygen sensor temperature is stable at $700^{\circ} \pm 10^{\circ}\text{C}$.
- Scroll the display using the up and down arrow keys until the combustibles sensor temperature is displayed. Check that the combustibles sensor temperature is stable at $300^{\circ} \pm 10^{\circ}\text{C}$.

5.4 Analogue output span setup

Refer to the Servomex 2700 QuickStart manual .

- If a zirconia sensor is fitted then select the **SET OUTPUTS** option in the **SERVICE** menu and select **20mA** for the oxygen analogue output. Check the current at TB2/15 & 16 in the control unit is $20.00 \pm 0.01\text{mA}$; if necessary, adjust RV4 on the control unit PCB until the analogue output reads $20.00 \pm 0.01\text{mA}$.
- If a combustibles sensor is fitted then select the **SET OUTPUTS** option in the **SERVICE** menu and select **20mA** for the combustibles output. Check the current at TB2/17 & 18 in the control unit is $20.00 \pm 0.01\text{mA}$; if necessary, adjust RV3 on the control unit PCB until the analogue output reads $20.00 \pm 0.01\text{mA}$.

5.5 Sensor head sample flow adjustment

With the 2700 analyser powered and the sensor head at a stable temperature, adjust the aspirator air supply pressure so that the value indicated on the label in the sensor head terminal enclosure is achieved at the sensor head. This produces a sample flow of 200 to 300 ml/min. Allowance should be made for pressure loss between the indicator and the sensor head where necessary.

5.6 Combustibles sensor zero adjustment

If a combustibles sensor is fitted then refer to Figure 12 and perform the following check and adjustments, if necessary:

- Apply an air sample to the calibration gas inlet at 600 to 800ml/min flow rate for at least 5 minutes.
- Using the keypad select the VIEW menu entry and scroll using up and down arrow keys to select the combustibles sensor output voltage.
- Check that the sensor output voltage is less than 60mV (positive or negative). If not, check the installation wiring.

- If the installation appears correct, set SW2 on the control PCB to the zero position. If the voltage measured is positive, set SW3 to the lower position (towards the bottom of the unit). If the voltage measured is negative, set SW3 to the upper position (towards the top of the unit).
- Adjust SW2 clockwise one step at a time, until the sensor voltage is less than 60mV (positive or negative). Note there will be a lag of up to 30 seconds between a switch change and the voltage response.

5.7 Sensor calibration

The sensor head must be powered and at a stable temperature for a minimum of 24 hours.

Refer to the Servomex 2700 QuickStart manual.

- Apply an air sample to the calibration gas inlet at a flow rate of 600 to 800ml/min. Perform a HIGH point calibration of the zirconia sensor (if fitted) and a LOW point calibration of the combustibles sensor (if fitted).
- Apply a nominal 0.3% O₂ in N₂ gas mixture to the calibration gas inlet at a flow rate of 600 to 800ml/min. Perform a LOW point calibration of the zirconia sensor (if fitted). Verify that the analyser display reads the correct gas concentration, as set in the calibration procedure.
- Apply a nominal 1000ppm(v) CO in air gas mixture to the calibration gas inlet at a flow rate of 600 to 800ml/min. Perform a HIGH point calibration of the combustibles sensor (if fitted). Verify that the analyser display reads the correct gas concentration, as set in the calibration procedure.

NOTE

After initial startup and calibration it is recommended that the calibration, catchpots and air filter are checked within the 5 to 10 days.

6 MAINTENANCE AND SERVICING

This section refers to installation of the analyser. For technical descriptions, fault diagnosis information, parts removal, refitting and test instructions, tool and test equipment lists, a Service Manual is available for use by qualified personnel, part number **02700002C**.



OPENING COVERS

The covers may only be opened during installation or servicing if there is negligible risk of pollution of the electronic circuits due to moisture, liquids, dirt, dust or other form of contamination.

Before refitting the covers, ensure the sealing gasket is clean, dry and undamaged. All covers should be replaced and secured as soon as possible after completing the operation.



CLEANING

In order to avoid dirt or water entering the enclosures when the covers are opened, the external surfaces of the analyser should be clean and dry before any cover is opened. Remove dust and loose particles with a soft brush. Wipe the surfaces thoroughly with a clean cloth, moistened with water. **CAUTION**... the sensor head may be hot.

It is recommended that the analyser should have its calibration checked once a month, and catch pots and air filters should be checked every three months. These times can then be adjusted depending on site experience.

Analyser flow rates, air supplies, probes and filters (internal and external), should be checked once per year, as well as the whole analyser and cabling for signs of wear. In more rugged applications, these times may need to be shorter, depending on experience.

This page is intentionally blank

Appendix A INTERCONNECTING WIRING SCHEDULES

The interconnecting wiring specification is given in Table 12. Wiring schedules for the oxygen only, the combustibles only and the dual sensor versions are given in Tables 13, 14 and 15 accordingly.

The electrical terminations in the Servomex 2700 are suitable for 20AWG (0.5mm²) to 14AWG (2.5mm²) solid and 16AWG (1.5mm²) stranded conductors. Both the Control Unit and Sensor Head have independent AC power supplies.

The maximum loop resistance limit of 4 ohms is required only for the sensor heater lines (2 lines per sensor). The sensor outputs, temperature signals and bridge supply wires need not be limited by this restriction on resistance. Depending on installation environment it may prove more cost effective to use interconnecting cables with more twisted pairs but with a smaller cross section per core and where necessary to run heater wires in parallel to produce the required minimum loop resistance of 4 ohms.

Table 12 – Interconnecting cable requirements			
Oxygen only	3 twisted pairs with overall screen. Minimum 0.5mm ² cross section. Maximum heater loop resistance 4 ohms.	1.0mm ²	100m
		1.5mm ²	150m
		2.5mm ²	300m
Combustibles only	6 twisted pairs individually screened and overall screened. Minimum 0.5mm ² cross section. Maximum heater loop resistance 4 ohms.		100m max.
Oxygen and combustibles See Note 2	Minimum 9 twisted pairs individually screened and overall screened. 0.5mm ² cross section. Maximum heater loop resistance 4 ohms.		100m max.
<i>Note 1:</i> For optional sensor head temperature display and the sensor head temperature high and sensor head temperature low faults at control unit, add 1 extra twisted pair to cable specification.			
<i>Note 2:</i> Recommend 12 twisted pairs, individually screened and overall screened 0.5mm ² cross section conductors. Use 2 pairs for the Ziconia sensor heater. Cable and gland sizes may vary depending on the manufacturer. Always check that the outside diameter of the cable is suitable for the gland being specified.			

Recommended Cables and Suppliers (Always check manufactures specification for full compatibility before use).		
Analyser	Cable Supplier	Part Number
Oxygen Only	Alpha.....	5610B2004
	Belden.....	1056A
Combustibles Only	Alpha.....	5620B2008
	Belden.....	1077A
Oxygen and Combustibles	Alpha.....	5620B2012
	Belden.....	1078A

Figure 13 Oxygen sensor only interconnection wiring schematic

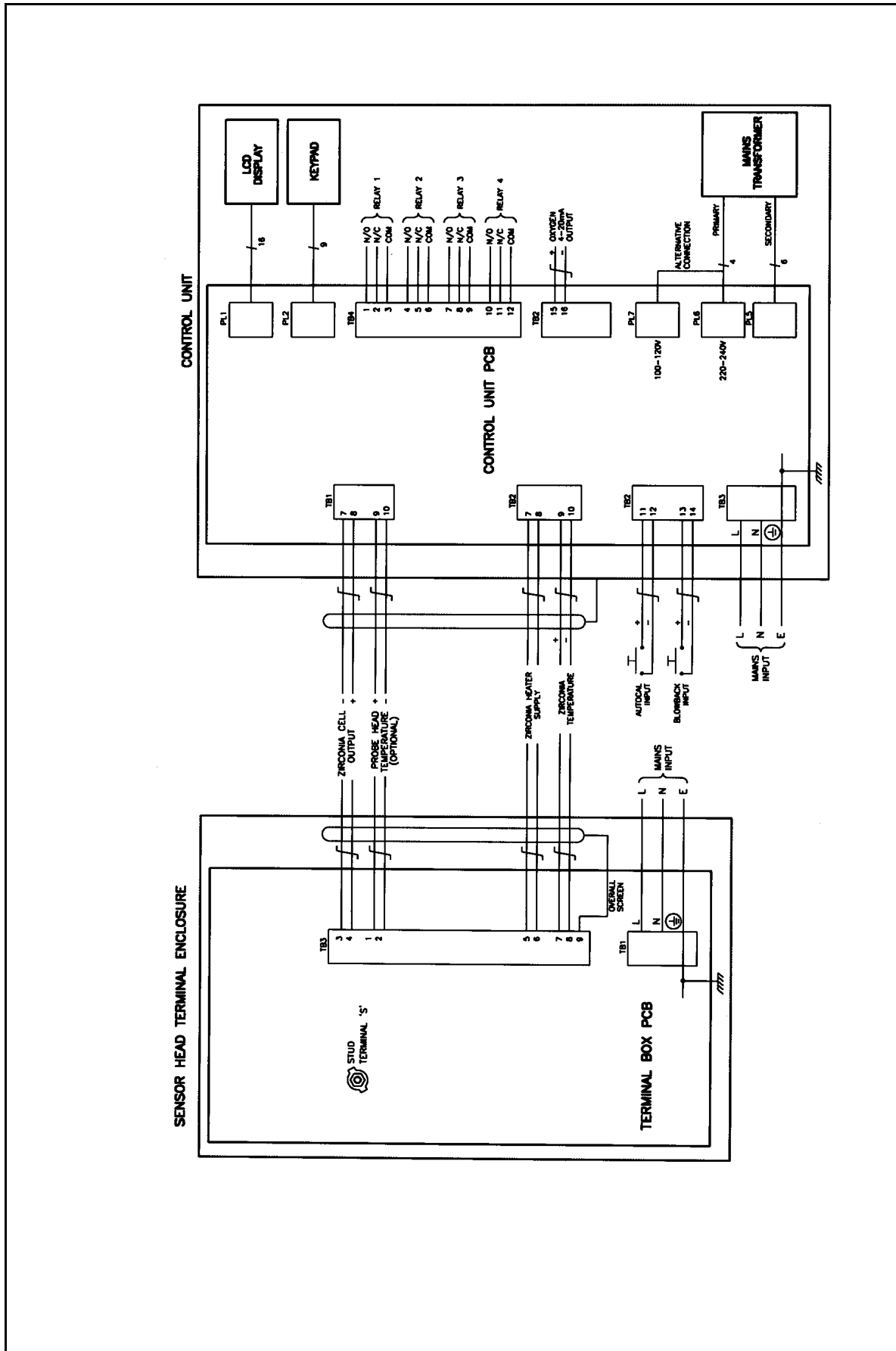

Table 13 – Oxygen sensor only interconnecting wiring			
Sensor head terminal	Function		Control unit terminal
TB3-1	Optional sensor head temperature measurement	+ve	TB1-9
TB3-2		-ve	TB1-10
TB3-3	Zirconia cell output	-ve	TB1-7
TB3-4		+ve	TB1-8
TB3-5	Zirconia sensor heater supply (polarity not important)		TB2-7
TB3-6			TB2-8
TB3-7	Zirconia sensor temperature output	+ve	TB2-9
TB3-8		-ve	TB2-10
TB3-9	Overall cable screen connection *		Enclosure
* for correct earthing details see Section 4.2			

Figure 14 Combustibles only interconnection wiring schematic

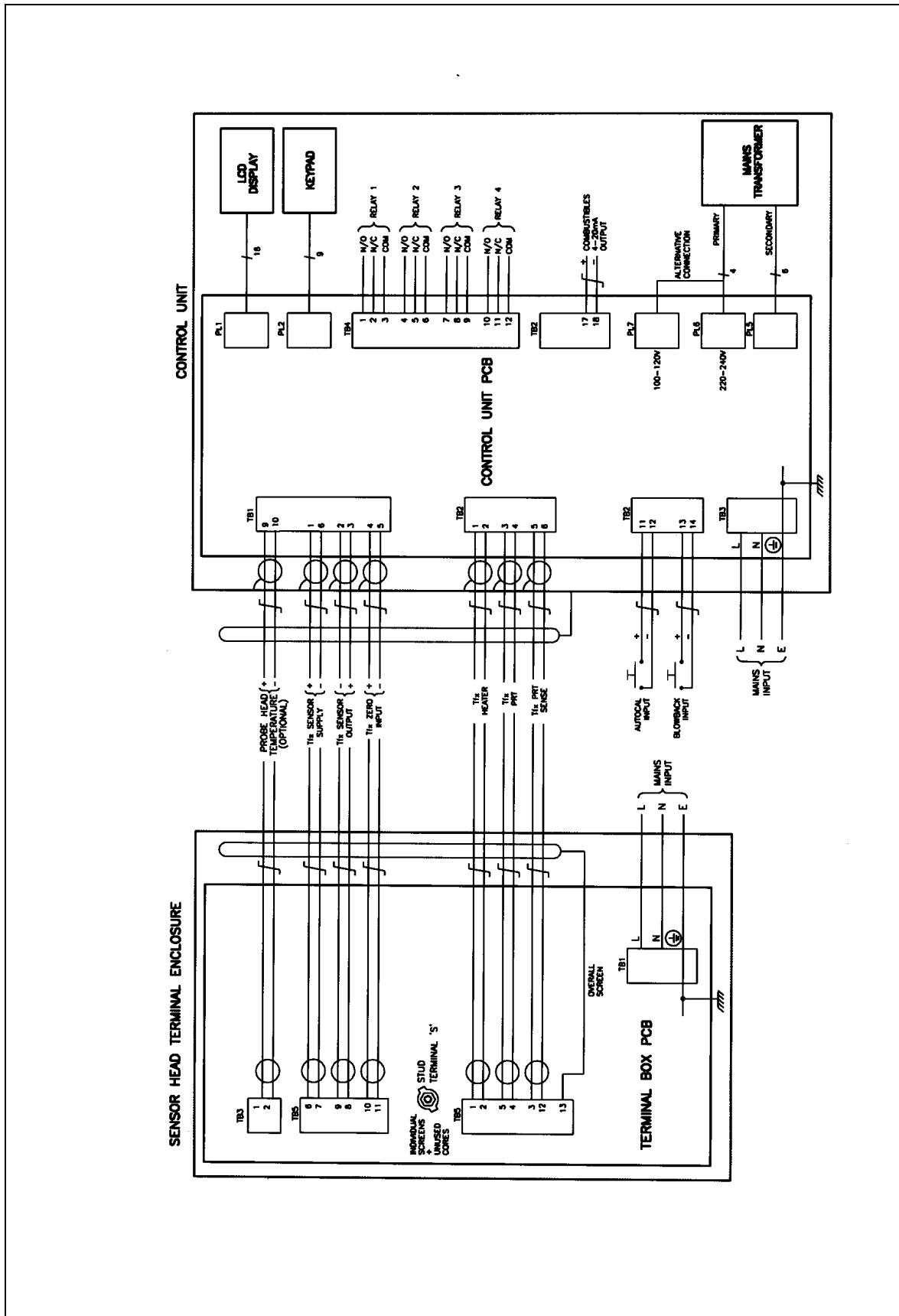

Table 14 – Combustibles only interconnecting wiring			
Sensor head terminal	Function		Control unit terminal
TB5-1	Combustibles sensor heater supply (polarity not important)		TB2-1
TB5-2			TB2-2
TB5-3	Combustibles sensor temperature output	sense	TB2-5
TB5-4		-ve	TB2-4
TB5-5		+ve	TB2-3
TB5-6	Combustibles sensor bridge supply	+ve	TB1-1
TB5-7		-ve	TB1-6
TB5-8	Combustibles sensor bridge output	+ve	TB1-3
TB5-9		-ve	TB1-2
TB5-10	Combustibles sensor bridge offset correction	+ve	TB1-4
TB5-11		-ve	TB1-5
TB5-12	Combustibles sensor temperature output	ground	TB2-6
Stud terminal 'S'	Individual screens and unused cores		Enclosure
TB5-13	Overall cable screen connection *		Enclosure
* for correct earthing details see Section 4.2			

Table 15 – Dual sensor interconnecting wiring			
Sensor head terminal	Function		Control unit terminal
TB5-1	Combustibles sensor heater supply (polarity not important)		TB2-1
TB5-2			TB2-2
TB5-3	Combustibles sensor temperature output	sense	TB2-5
TB5-4		-ve	TB2-4
TB5-5		+ve	TB2-3
TB5-6	Combustibles sensor bridge supply	+ve	TB1-1
TB5-7		-ve	TB1-6
TB5-8	Combustibles sensor bridge output	+ve	TB1-3
TB5-9		-ve	TB1-2
TB5-10	Combustibles sensor bridge offset correction	+ve	TB1-4
TB5-11		-ve	TB1-5
TB5-12	Combustibles sensor temperature output	ground	TB2-6
TB5-13	Overall cable screen connection *		Enclosure
TB3-1	Optional sensor head temperature measurement	+ve	TB1-9
TB3-2		-ve	TB1-10
TB3-3	Zirconia cell output	-ve	TB1-7
TB3-4		+ve	TB1-8
TB3-5	Zirconia sensor heater supply (polarity not important)		TB2-7
TB3-6			TB2-8
TB3-7	Zirconia sensor temperature output	+ve	TB2-9
TB3-8		-ve	TB2-10
Stud terminal 'S'	Individual screens and unused cores		Enclosure
* for correct earthing details see Section 4.2			

NOTES